

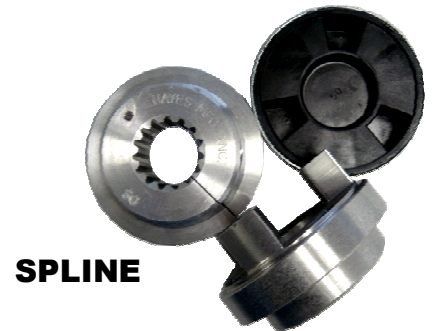

Hayes Jaw Couplings

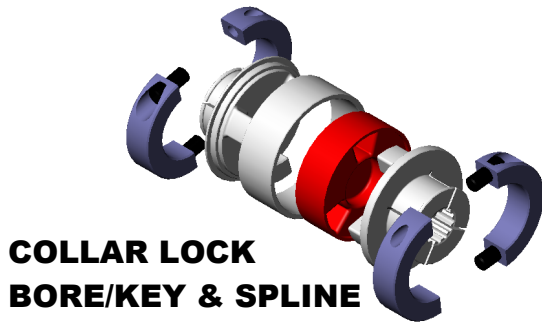

Hayes Jaw Couplings

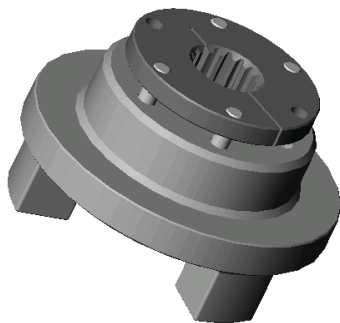

NEOPRENE

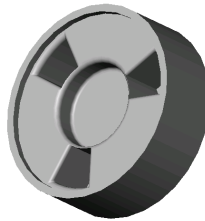

BORE & KEY

METAL RING



HYTREL

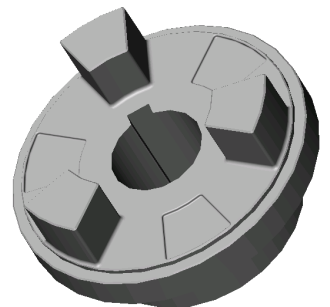
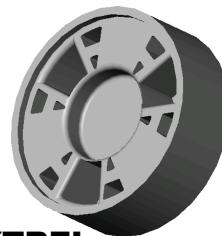

Hayes Manufacturing, Inc.

6875 U.S. 131

Fife Lake, MI 49633

Phone: (231) 879-3372 Fax: (231) 879-4330

Visit us at www.hayescouplings.com

HAYES

™

MANUFACTURING, INC.

For many years, Hayes Manufacturing, Inc. has been dedicated to becoming a leader in the manufacturing of coupling products. Our commitment to quality and product improvement has made us a stand-out in a very competitive market.

In 1966, we started our family business in a garage in Rochester, Michigan. In 1978, we developed the first Hayes Flexible Drive Coupling to satisfy our customers needs. That first coupling was the predecessor for a successful and ever-increasing product line.

In 1990, the demand for our products forced us to expand. We moved our employees into a new 25,000 sq. ft. plant in the Grand Traverse Hills Industrial Center in Fife Lake, Michigan.

We employ skilled personnel to operate our state-of-the-art equipment. To ensure that quality expectations will be met, our employees have been trained for Statistical Process Control (SPC). This inspection procedure ensures that parts are continually checked during production and adjustments are made to keep them within specifications.

Our new plant has enabled us to carry a large inventory of products for prompt delivery as well as to fine-tune our business in areas that will be a benefit to our valued customers.



In an ongoing effort to continue to bring you quality products and services, we are under going ISO 9000:2000 training and will be certified in the fourth quarter of 2001.

FLEXIBLE DRIVE COUPLINGS

Our flexible coupling product line makes a positive impact on industries using power units, hydrostatic drives, etc.

We maintain an extensive inventory and strive to ship stock items within a 12 to 24 hour period.

Our products are marketed through a knowledgeable, customer-oriented distributor network.

Our goal is to provide the quality products and service our customers expect from a world class company in order to help maximize their success.





This simple, three piece, quality built, flexible coupling is generally used to connect an electric motor to a hydraulic pump or mechanical drive.

The hubs are made of a strong, lightweight aluminum alloy. The bodies and lugs are precision machined on CNC equipment to assure proper fit every time. Two set screws are standard. The solid wall of rubber in the insert eliminates metal-to-metal contact and provides a clean, quiet, trouble-free performance when aligned properly.

The unique steel locking insert is standard on all splined couplings in the 20 through 60 series. For the mobile market, taper lock splines are also available in the same series.

Three insert choices are available. Neoprene, Hytrel* and Neoprene with a metal ring. Neoprene is used for light or steady loads. Hytrel*, for industrial application where torque, a variety of load conditions or chemicals exist. Neoprene with a metal ring for medium and heavy torque conditions and internal combustion engine applications.

Installation requires only a straight edge and feeler gage to insure proper alignment. For longer insert life, misalignment should not exceed .005 parallel or 1° angular.

XO SERIES 5/8" Max. Bore

MAX. FRAME SIZE: 48
MAXIMUM RECOMMENDED TORQUE: .75 Horsepower at 1800 RPM

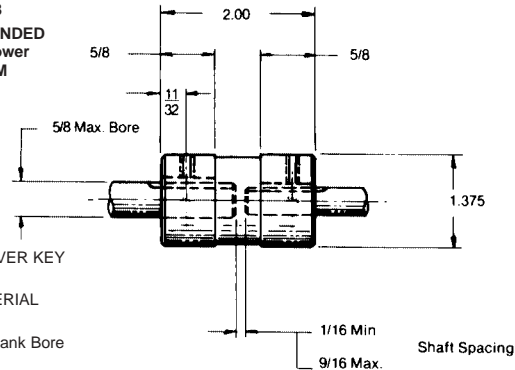

- Drive insert will accept a 1/2" shaft
- ONE SET SCREW OVER KEY This series only
- DRIVE INSERT MATERIAL Hytrel*
- APPROX. WEIGHT Blank Bore 4oz.

10 SERIES 1" Max. Bore

MAX. FRAME SIZE: 145T 184
MAXIMUM RECOMMENDED TORQUE: 2.7 Horsepower at 1800 RPM

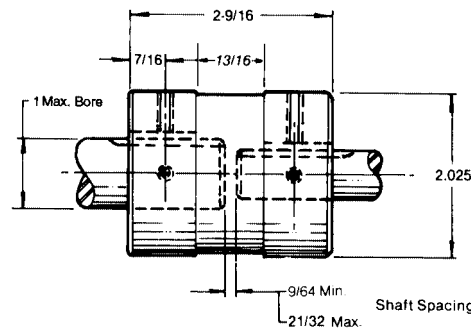

- Drive insert will accept a 7/8" shaft
- DRIVE INSERT MATERIAL Hytrel* or Neoprene
- APPROX. WEIGHT Blank Bore 10 oz.

20 SERIES 1-3/8" Max. Bore

MAX. FRAME SIZE: 184T 215
MAXIMUM RECOMMENDED TORQUE: 5.1 Horsepower at 1800 RPM

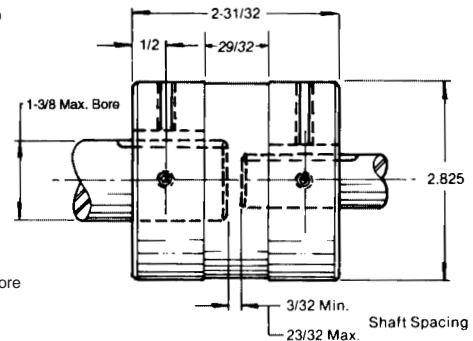

- Drive insert will accept a 1-1/8" shaft
- DRIVE INSERT MATERIAL Hytrel* or Neoprene
- APPROX. WEIGHT Blank Bore 1-1/2 lbs.

30 SERIES 1-5/8" Max. Bore

MAX. FRAME SIZE: 215T 256U
MAXIMUM RECOMMENDED TORQUE: 10.2 Horsepower at 1800 RPM

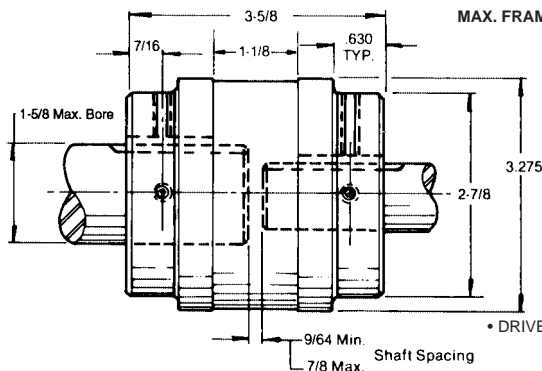

- Drive insert will accept a 1-3/8" shaft
- DRIVE INSERT MATERIAL Hytrel* or Neoprene
- APPROX. WEIGHT Blank Bore 2-1/2 lbs.

40 SERIES

1-7/8" Max. Bore

MAX. FRAME SIZE:
256T & 286TS
286Y 326S

MAXIMUM RECOMMENDED
TORQUE: 30.0 Horsepower
at 1800 RPM

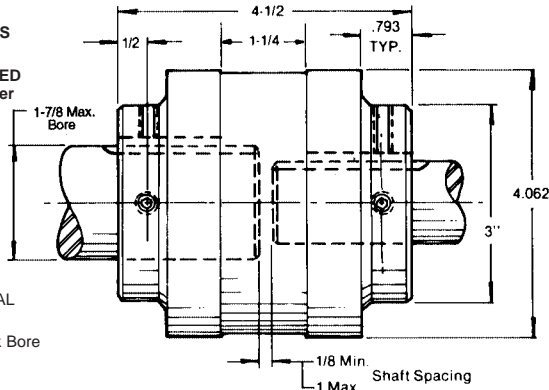

- Drive insert will accept a 1-3/4" shaft
- DRIVE INSERT MATERIAL Hytrel® or Neoprene
- APPROX. WEIGHT Blank Bore 4 lbs.

50 SERIES

2-3/8" Max. Bore

MAX. FRAME SIZE:
326 405TS 365U

MAXIMUM RECOMMENDED
TORQUE: 75.0 Horsepower
at 1800 RPM

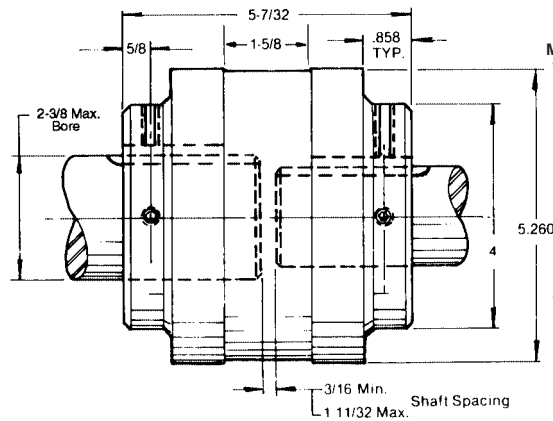

- Drive insert will accept a 2 1/4" shaft
- DRIVE INSERT MATERIAL Hytrel® or Neoprene
- APPROX. WEIGHT Blank Bore 8 lbs.

60 SERIES

2-7/8" Max. Bore

MAX. FRAME SIZE:
365T & 445TS
405U 445US

MAXIMUM RECOMMENDED
TORQUE: 114.1 Horsepower
at 1800 RPM

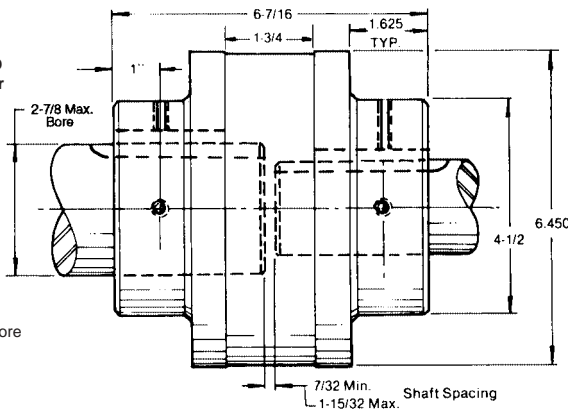

- Drive insert will accept a 2-3/4" shaft
- DRIVE INSERT MATERIAL Hytrel® or Neoprene
- APPROX. WEIGHT Blank Bore 12 lbs.

HAYES STEEL LOCKING INSERT

STANDARD ON ALL SPLINED COUPLINGS 20 THROUGH 60 SERIES

For spline shaft applications, we use a split system and steel locking insert to provide more holding power and to protect splined shafts. It is commonly used on power units and hydrostatic drives.



SPLIT LOCKING SYSTEM

INSTALLATION INSTRUCTIONS

1. Tighten socket head cap screw for split locking system.
2. Tighten set screw on large diameter to bring steel locking insert down against shaft.

TAPER LOCK SYSTEM

STANDARD ON ALL SPLINED COUPLINGS
20 THROUGH 60 SERIES

The Hayes taper lock bushings are competitively priced, strong, durable, and used primarily in the mobile market. The tapers are drawn together with socket head cap screws which are tightened from the lug side of the coupling, allowing you to get closer to the pump face.

The steel taper lock bushing provides uniform pressure on the shaft to help prevent movement and the resulting damage.



DRIVE INSERTS

HYTREL*

Drive Insert

Designed for INDUSTRIAL applications where torque and a variety of load conditions exist. It also has good chemical and abrasion resistance. Temperature range -65°F to +250°F (-54°C to +121° C).



NEOPRENE

Drive Insert

Typically used where light or steady load conditions exist, also resists degradation from sun, ozone and weathering. Temperature range from 0°F to +220°F (-18°C to 104°C). A Metal Ring is recommended for medium and heavy torque conditions, as well as internal combustion engine applications.



Metal Ring

For Neoprene Insert ONLY

A Metal Ring is recommended (only for neoprene inserts) for medium and heavy torque conditions, as well as internal combustion engine applications.

The Ring slips over the insert to contain the rubber and increases load capacity.

May be used in some cases to allow over size bores in next smaller series coupling. Consult factory for more information.



Our flexible drive coupling has been **TESTED BY THE UNIVERSITY OF MICHIGAN MECHANICAL ENGINEERING DEPARTMENT**. The guide below gives you the usable results of these tests. A safety factor of 3 applied to the recommended maximum torque shown in the guide.

Before ordering you need to know the following:

1. Type of prime mover and load classification.
2. Shaft diameter and key size.
3. Horsepower rating of prime mover.
4. Maximum operating speed (R.P.M.).

Ordering Instructions:

- A. To locate your proper coupling series, use the service factor guide below and locate your prime mover and load classification. (Example: a 30 H.P. electric motor for a pump with medium load application=1.5 service factor.)
- B. Multiply the H.P. of load to be transmitted by S.F. then divide by 3. (Example: 30 H.P. x 1.5 S.F. = 45 H.P. ÷ 3 = 15 H.P.)
- C. With this figure, refer to the performance data guide and locate the R.P.M.s at which your motor operates (Example: 1800 R.P.M.s).
- D. Move down the chart until you come to the first H.P. larger than you need. (Example: 1-5/8 shaft x 3/8 key = 40 Series H.P.) If Neoprene is used a metal ring is recommended.

SERVICE FACTOR GUIDE			
Load Classification	PRIME MOVER		
	Electric Motor or Turbine	6 or more Cyl. Gas or Diesel Eng.	Less than 6 Cyl. Gas or Diesel Eng.
Light or Uniform Load • BLOWERS • FANS EVEN OR STEADY LOAD • CONVEYORS • AGITATORS NON-REVERSING • CENTRIFUGAL PUMPS	1.0	1.5	*2.0
Medium or Moderate Load • ELEVATORS MODERATE SHOCK • MIXERS UNEVEN LOAD • MACHINE TOOLS INFREQUENT REVERSING • RECIPROCATING PUMPS	1.5	*2.0	*2.5
Heavy Load HEAVY SHOCK • SHAKER CONVEYORS UNEVEN LOAD • CRUSHERS • PRESSES FREQUENT REVERSING • WINCHES	*2.0	*2.5	3.0 <small>Neoprene with Metal Ring Only</small>

NOTE-Use as general guide only

Optional: *Hytrel[®] or Neoprene with Metal Ring

PERFORMANCE DATA GUIDE															
Coupling Series	Coupling Size			Maximum Recommended Torque in lbs	Maximum + Torque in lbs	Maximum R.P.M.									
	Outside Dia.	Overall Length	Max. Bore			HORSEPOWER	100	300	600	900	1200	1500	1800	2400	3000
X0	1.375	2.00	5/8		26	.04	.12	.25	.37	.50	.62	.75	1.0	1.2	1.5
10	2.025	2.56	1	900	96	.15	.45	.91	1.37	1.82	2.28	2.7	3.6	4.56	5.4
20	2.825	2.96	1 3/8	2,150	180	.28	.85	1.71	2.57	3.42	4.28	5.1	6.8	8.5	10.2
30	3.275	3.62	1 5/8	3,000	362	.57	1.71	3.42	5.14	6.85	8.56	10.2	13.7	17.1	20.5
40	4.062	4.50	1 7/8	4,500	1052	1.66	5.00	10.01	15.01	20.01	25.01	30.0	40.0	50.0	60.0
50	5.260	5.21	2 3/8	9,000	2628	4.16	12.50	25.01	37.52	50.03	62.54	75.0	100.0	125.0	150.1
60	6.450	6.43	2 7/8	13,500	3996	6.34	19.02	38.04	57.06	76.08	95.10	114.1	152.1	190.2	228.2

*hub strength static tested by University of Michigan, Mechanical Engineering Department

+safety factor of three applied

h.p. and torque ratings are for aluminum couplings, for rating on steel (special) consult factory.

Hayes Manufacturing has a new line of couplings that fit through standard SAE pump pilots. To order: Please specify a "C" after your option number. Example: 1A0-07C-00 is a 10 series aluminum 3/4 bore 3/16 key.

10 SERIES

1" Max. Bore

MAX. FRAME SIZE:
145T 184
MAXIMUM RECOMMENDED
TORQUE: 2.7 Horsepower
at 1800 RPM

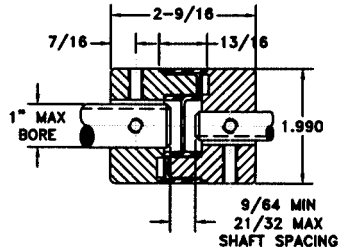

- Drive insert will accept a 7/8" shaft
- DRIVE INSERT MATERIAL Hytrel® or Neoprene
- APPROX. WEIGHT Blank Bore 10 oz.

20 SERIES

1-3/8" Max. Bore

MAX. FRAME SIZE:
184T 215
MAXIMUM RECOMMENDED
TORQUE: 5.1 Horsepower
at 1800 RPM

THIS IS A STANDARD HAYES FLEXIBLE COUPLING. THE "C" IS NOT NEEDED FOR ORDERING THIS SIZE.

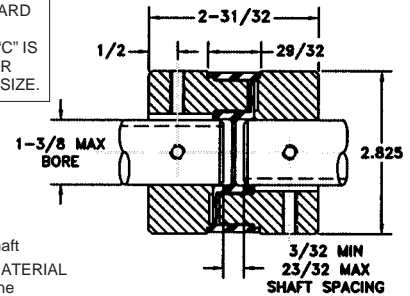

- Drive insert will accept a 1-1/8" shaft
- DRIVE INSERT MATERIAL Hytrel® or Neoprene
- APPROX. WEIGHT Blank Bore 1-1/2 lbs.

30 SERIES

1-5/8" Max. Bore

MAX. FRAME SIZE:
215T 256U
MAXIMUM RECOMMENDED
TORQUE: 10.2 Horsepower
at 1800 RPM

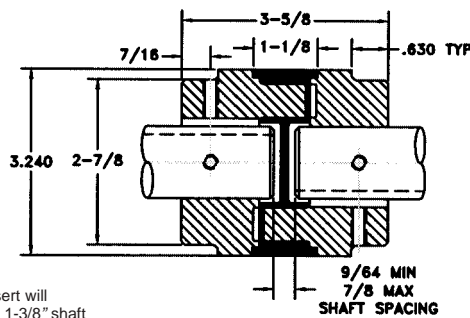

- Drive insert will accept a 1-3/8" shaft
- DRIVE INSERT MATERIAL Hytrel® or Neoprene
- APPROX. WEIGHT Blank Bore 2-1/2 lbs.

40 SERIES

1-7/8" Max. Bore

MAX. FRAME SIZE:
326 405TS 365U
MAXIMUM RECOMMENDED
TORQUE: 30 Horsepower
at 1800 RPM

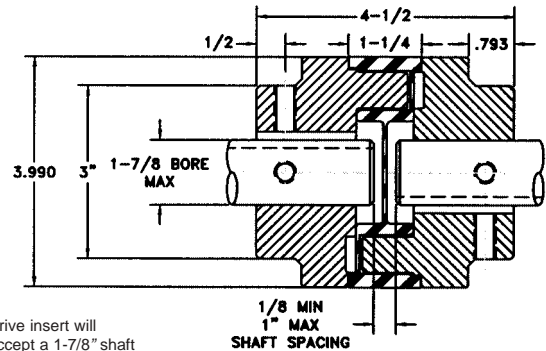

- Drive insert will accept a 1-7/8" shaft
- DRIVE INSERT MATERIAL Hytrel® or Neoprene
- APPROX. WEIGHT Blank Bore 4 lbs.

50 SERIES

2-3/8" Max. Bore

MAX. FRAME SIZE:
326 405TS 365U
MAXIMUM RECOMMENDED
TORQUE: 75 Horsepower
at 1800 RPM

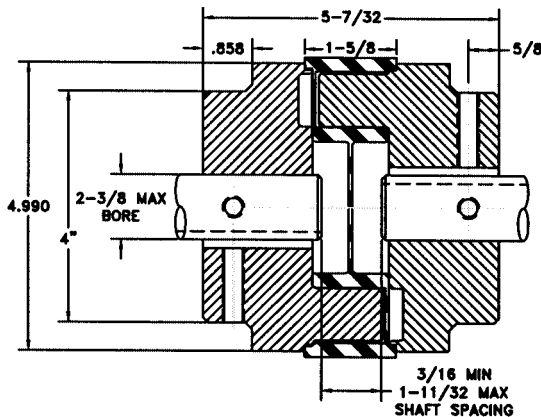

- Drive insert will accept a 2-1/4" shaft
- DRIVE INSERT MATERIAL Hytrel® or Neoprene
- APPROX. WEIGHT Blank Bore 8 lbs.

60 SERIES

2-7/8" Max. Bore

MAX. FRAME SIZE:
365T 445TS 405U 445US
MAXIMUM RECOMMENDED
TORQUE: 114.1 Horsepower
at 1800 RPM

THIS IS A STANDARD HAYES FLEXIBLE COUPLING. THE "C" IS NOT NEEDED FOR ORDERING THIS SIZE.

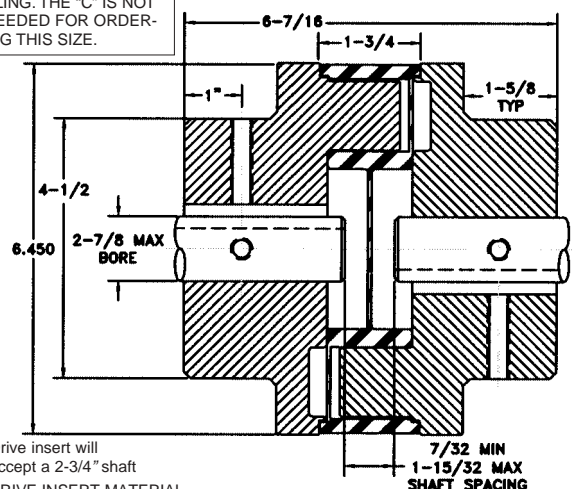

- Drive insert will accept a 2-3/4" shaft
- DRIVE INSERT MATERIAL Hytrel® or Neoprene
- APPROX. WEIGHT Blank Bore 12 lbs.

EASY ALIGNMENT OF THE HAYES FLEXIBLE DRIVE COUPLING

Install couplings on pump and motor shafts.

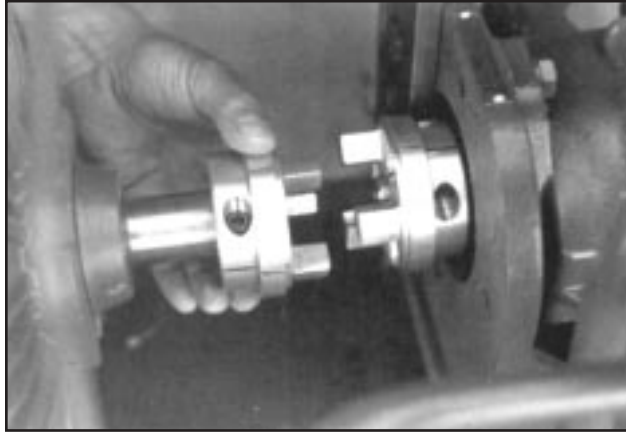

Misalignment is easily detected with a straight edge and using a .005 feeler gage on top and side of coupling will give ample alignment.

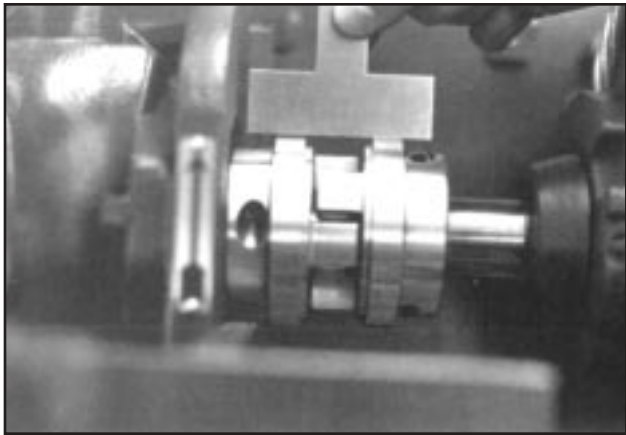

Use drive insert between dirt seals for gage to determine distance between coupling halves, leaving approximately $1/32$ clearance per side. **(Insert should not run in compressed state.)**

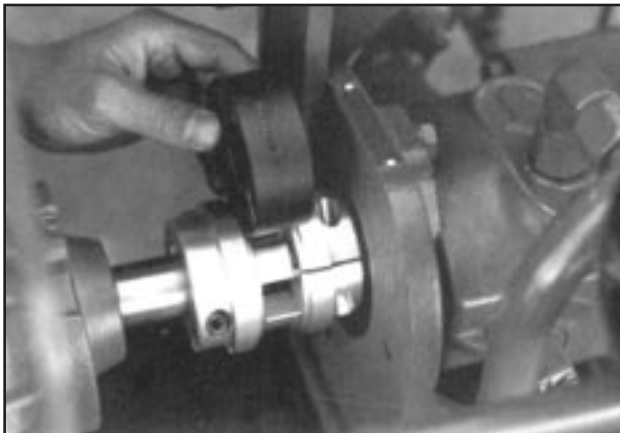

Recheck alignment with straight edge and tighten. (Coupling can also be aligned with insert installed.) No more than 1° maximum angular misalignment.

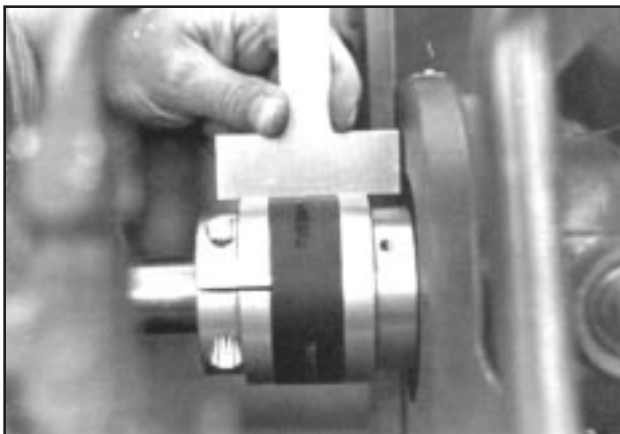

- Please remember that if excess vibration or misalignment are present in your system it will cause the rubber insert to wear rapidly.
- The rubber element is the safety factor in your system. It could protect the system from serious damage caused by either of these two conditions.
- We strongly recommend accurate alignment and minimum vibration when using a flexible coupling in order to obtain maximum life.